

Stamped Steel — Ideal for Construction

LHH Hand Chain Hoist

COFFING LHH Models - Stamped steel hand chain hoists are an excellent low cost option in the Coffing line. The compact, lightweight design is ideal for construction and contractor applications where portability and easy rigging are critical.

- **CAPACITIES & LIFT** - Rated loads from 1/2 to 20 Tons in stock with standard lifts of 10, 15, and 20 feet. Standard hand chain drop is 2-feet less than lift. Other lifts and hand chain drops, and 25 - 50 Ton models available — consult factory.
- **COMPACT AND LIGHTWEIGHT** - Designed for portability and easy installation. Compact gear housing provides low headroom.
- **EASY TO OPERATE** - Lubricated bearings and bushings, bearing-mounted pinions, and heat-treated spur gearing ensure smooth and efficient operation with minimal effort.
- **SAFETY & LOAD CONTROL** - Mechanical load brake engages instantly for precise load holding and positioning. 360° swivel hooks with safety latches for positive load engagement.
- **DURABLE** - Through hardened load chain provides added strength and wear resistance for greater chain life. Stamped steel housing withstands rugged conditions.
- **EASY TO MAINTAIN** - Designed for easy inspection and maintenance. Hoist can be dismantled easily with simple hand tools.
- **LIFETIME WARRANTY**



1/2 - 50 Ton

S P E C I F I C A T I O N S

LHH Hand Chain Hoists

Capacity		Model Number	Lifts (Ft.) **	Strands of Load Chain	Minimum Headroom (In.)	Average Overhaul for 1 Ft. Lift (Ft.)	Net Pull to Lift Rated Load (Lbs.)	Weight for 10 Ft. Lift (Lbs.)
Lbs.	Tons							
1000	1/2	LHH-1/2	10/15/20	1	10 ¹ / ₄	32	55	19
2000	1	LHH-1	10/15/20	1	11 ¹³ / ₁₆	56	53	25
3000	1 1/2	LHH-1 1/2	10/15/20	1	13 ⁹ / ₁₆	75	65	36
4000	2	LHH-2	10/15/20	1	15	75	74	45
6000	3	LHH-3	10/15/20	1	17 ¹ / ₈	95	84	66
10000	5	LHH-5	10/15/20	3	22 ⁵ / ₈	203	79	75
16000	8	LHH-8	10/20	3	32 ¹ / ₂	312.5	77	158
20000	10	LHH-10	10/20	3	32 ¹ / ₂	312.5	95	158
24000	12	LHH-12	10/20	5	50 ⁵ / ₈	526	84	328
30000	15	LHH-15	10/20	5	50 ⁵ / ₈	526	103	328
40000	20	LHH-20	10	6	52 ³ / ₈	312.5 x 2 †	99 x 2 †	535
50000	25*	LHH-25	10	8	52 ⁷ / ₈	416.7 x 2 †	97 x 2 †	680
60000	30*	LHH-30	10	10	65	526.3 x 2 †	104 x 2 †	945
80000	40*	LHH-40	10	14	73 ⁵ / ₁₆	714.3 x 2 †	101 x 2 †	1400
100000	50*	LHH-50	10	20	77 ⁵ / ₈	1000 x 2 †	104 x 2 †	1840

* 25, 30, 40, and 50 Ton models available by special order — consult factory.

** Standard lifts shown. Other lifts available — consult factory.

† LHH-20 through LHH-50 models have two hand chains.

NOTE: For complete dimensional data, refer to Coffing Dimensional Databook.

LHH 1/2 to 50 Ton

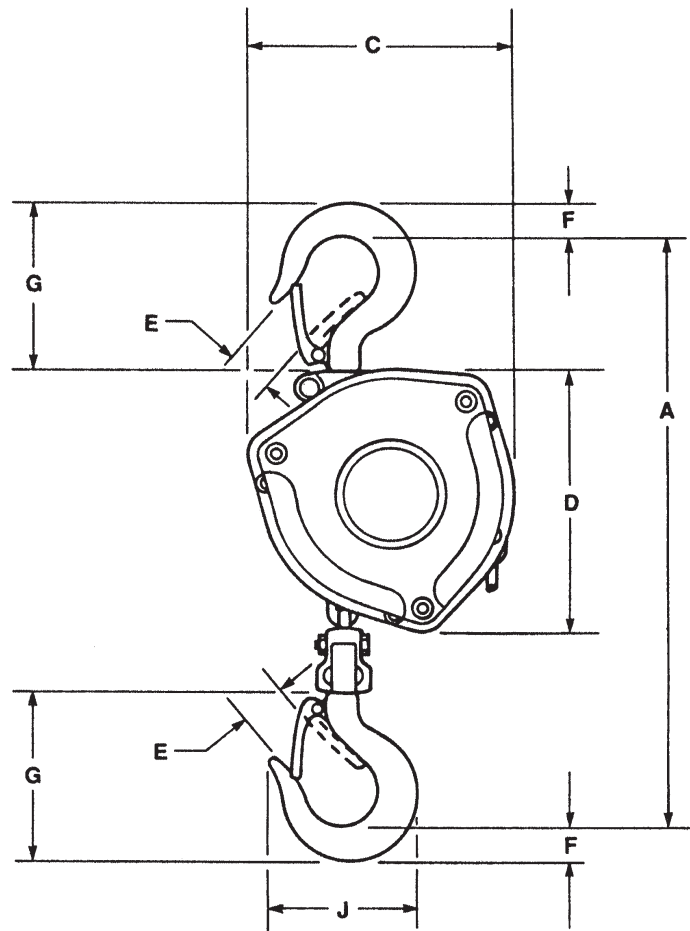
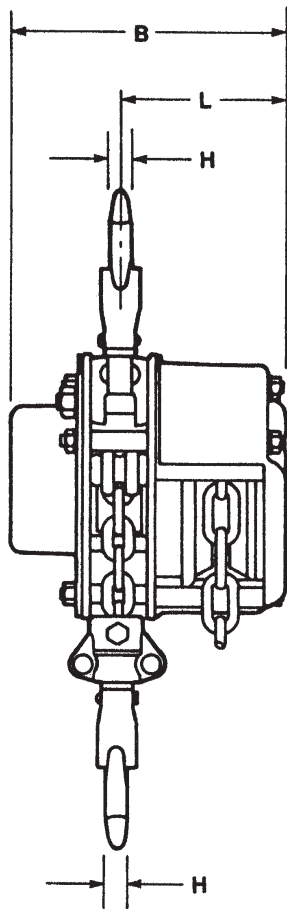

Dimensions

Model Number	Rated Load (Ton)	A	B	C	D	E	F	G	H	J	K	No. of Load Chains
LHH-1/2B	1/2	10 ¹ / ₄	5 ⁷ / ₁₆	5 ⁷ / ₁₆	5 ¹ / ₄	5 ⁵ / ₁₆	5 ⁵ / ₈	3 ³ / ₈	7 ¹ / ₁₆	2 ¹⁵ / ₁₆	3 ¹ / ₄	1
LHH-1B	1	11 ³ / ₁₆	5 ¹⁵ / ₁₆	6 ¹ / ₄	6	1 ¹ / ₈	5 ⁵ / ₁₆	4 ¹ / ₁₆	5 ⁵ / ₈	3 ¹⁹ / ₃₂	3 ⁷ / ₁₆	1
LHH-1 ¹ / ₂ B	1 ¹ / ₂	15 ³ / ₄	6 ¹ / ₂	7 ¹ / ₄	6 ¹ / ₈	1 ⁵ / ₁₆	1 ¹ / ₈	3 ⁹ / ₁₆	1 ³ / ₁₆	4	3 ⁵ / ₈	1
LHH-2B	2	15	7 ¹ / ₄	8 ⁷ / ₁₆	8 ¹ / ₂	1 ³ / ₈	1 ¹ / ₄	4 ¹⁵ / ₁₆	7 ⁷ / ₈	4 ⁹ / ₁₆	3 ⁷ / ₈	1
LHH-3B	3	17 ¹ / ₈	7 ¹³ / ₁₆	10	10	1 ⁹ / ₁₆	1 ¹ / ₂	5 ³ / ₄	1 ¹ / ₈	5 ⁷ / ₁₆	4 ³ / ₈	1
LHH-5B	5	22 ⁵ / ₈	6 ¹ / ₂	11 ¹ / ₈	7 ⁵ / ₁₆	1 ⁷ / ₈	1 ¹³ / ₁₆	6 ¹³ / ₁₆	1 ³ / ₈	6 ¹ / ₂	3 ⁵ / ₈	3
LHH-8B	8	32 ¹ / ₂	7 ¹³ / ₁₆	15 ¹ / ₁₆	—	2 ³ / ₄	2 ¹ / ₂	9 ¹⁷ / ₃₂	1 ¹³ / ₁₆	8 ³ / ₄	4 ³ / ₁₆	3
LHH-10B	10	32 ¹ / ₂	7 ¹³ / ₁₆	15 ¹ / ₁₆	—	2 ³ / ₄	2 ¹ / ₂	9 ¹⁷ / ₃₂	1 ¹³ / ₁₆	8 ³ / ₄	4 ³ / ₁₆	3
LHH-12B	12	50 ⁵ / ₈	7 ¹³ / ₁₆	20 ⁵ / ₁₆	—	2 ¹⁵ / ₁₆	2 ²⁷ / ₃₂	11 ³ / ₁₆	2 ⁷ / ₁₆	10 ¹¹ / ₁₆	4 ³ / ₁₆	5
LHH-15B	15	50 ⁵ / ₈	7 ¹³ / ₁₆	20 ⁵ / ₁₆	—	2 ¹⁵ / ₁₆	2 ²⁷ / ₃₂	11 ³ / ₁₆	2 ⁷ / ₁₆	10 ¹¹ / ₁₆	4 ³ / ₁₆	5
LHH-20B	20	52 ³ / ₈	12 ¹ / ₈	28 ⁷ / ₈	—	3 ¹ / ₈	3 ⁹ / ₁₆	12 ⁹ / ₁₆	3 ⁹ / ₁₆	12 ¹ / ₂	6 ¹ / ₁₆	6
LHH-25B	25	52 ⁷ / ₈	14 ¹ / ₂	28 ⁷ / ₈	—	3 ¹ / ₈	3 ¹ / ₂	12 ⁹ / ₁₆	3 ⁹ / ₁₆	12 ¹ / ₂	7 ¹ / ₄	8
LHH-30B	30	65	16 ⁷ / ₈	29 ⁵ / ₈	—	4 ³ / ₁₆	4 ³¹ / ₃₂	18 ³ / ₁₆	4 ⁷ / ₁₆	15 ³ / ₁₆	8 ⁷ / ₁₆	10
LHH-40B	40	73 ⁵ / ₁₆	20 ¹ / ₈	29 ⁵ / ₈	—	4 ¹ / ₁₆	6 ³ / ₁₆	22 ¹ / ₄	5 ¹ / ₄	17 ⁵ / ₈	10 ¹ / ₁₆	14
LHH-50B	50	77 ⁵ / ₈	25 ⁷ / ₈	29 ⁵ / ₈	—	4 ³ / ₄	6 ³ / ₄	23 ³ / ₄	6 ⁷ / ₈	20 ¹ / ₄	12 ¹⁵ / ₁₆	20

Dimensions are in inches unless otherwise indicated.